

CRIBUS E

MOBILE ELECTRIC DRUM SCREENS
WIDE RANGE OF APPLICATIONS
EFFICIENT ELECTRIC DRIVE
MORE PERFORMANCE PER SCREEN AREA
DUAL HYBRID POWER





HIGHLIGHTS

- » Designed for economical operation
- » Energy, wear and maintenance costs minimized through innovative solutions
- » Electrical drive of all components for the highest energy efficiency
- » Available in three sizes to meet any performance need
- » Extensive options for individual configuration
- » User-friendly and reliable through new machine design



CRIBUS E MORE UTILITY

The Cribus E series redefines the term mobile drum screen. Numerous innovations create a machine with the highest level of functionality and cost-effectiveness, to set a new benchmark. The drive system is the basis for its extremely high cost-effectiveness - everything on the Cribus E is driven electrically, from the hopper to the discharge belts.

This minimizes the energy, wear and servicing costs of the whole machine, backed up by the newly developed direct drum drive. The Cribus also offers compelling benefits in servicing and operational safety. Large flaps and doors, simple replacement of screen drum and conveyor belts, and well-designed safety mechanisms are hallmarks of the machine design.



01

Compost

Green compost, organic compost, sludge compost

Cribus drum screens demonstrate their talent for screening when used for composting. Controllable hopper and drum rotation speeds allow precise material alignment. Overfilling of the drum is prevented by load-dependent hopper control. The efficient cleaning brushes and uniquely generous clearance between drum and sidewalls prevent screen hole clogging, even with difficult materials. A standard screen drum or a drum with exchangeable screen segments can be used for screening, depending on requirements.



02

Wood/biomass

Shredded waste wood, woody biomass, wood chips, bark

Komptech drum screens are also effective with high-bulk material. Steep hopper sides prevent bridging, and a wide conveyor with T-cleats feeds the material into the drum reliably. The large feed cross-section prevents material compression between hopper and screen drum so that the entire drum length is used to full advantage, for efficient screening. Extended discharge belts allow for high piles, and with a width of up to 3' 3" / 1000 mm there are no blockages on the conveyor belt.



03

Soil/gravel

Excavated material, sand, gravel, light-weight building rubble

Heavy materials do not present problems for Cribus drum screens. Solid contaminants are kept back by a hinged hopper pre-screen. A hopper belt controller prevents skewing of the belt. Automatic antislip control on the drive ensures that the drum turns even under extreme loading. Controllable belt speed and bolt-on cleats on the oversize fraction belt keep stones from rolling back.



04

Waste

Shredded bulky, household and residual waste, refuse derived fuels

Ample space between screen drum and sidewalls also makes operation with large screen hole sizes go smoothly. For these hole sizes, outside scrapers are more effective than circular brushes for drum cleaning. For residual waste screening, a special drum with anti-dirt strips is also available. Large side doors and flaps provide easy access for cleaning and servicing.



01

More performance per foot

Despite being only 35 feet / 10.6 meters long, the Cribus 2800 E boasts a screening area of 301 ft² / 28 m², made possible by the large 7' 3" / 2.2 meter drum diameter. This makes material clumping between hopper and drum a thing of the past, so that the Cribus has a higher specific throughput (ft² per ft² / m³ per m² screening area) than competitors.



02

Broad range of applications

Steep sidewalls and a wide hopper belt prevent material bridging and enable screening of a wide range of materials. The large drum diameter and generous clearance to the sidewalls allow smooth screening of fractions with larger shapes and sizes, even with the 4" / 100 mm screen hole size.



03

Efficient drum drive

The new maintenance-free friction wheel drive with the patented WHEELGRIP anti-slip technology; gives maximum efficiency with minimum costs for wear and servicing, since there are no chains, gears or additional bearings.

HIGHLIGHTS

- » The largest screening surface of any machine of its length
- » 20% more feed cross-section than the competition
- » New WHEELGRIP patented chainless drum drive
- » Easily handles a wide range of materials with hole sizes up to 4" / 100 mm
- » Drum with fixed hole size or flexible drum system with interchangeable screen segments, as desired



CRIBUS 2800 E

THE NEW BENCHMARK

With the largest screening surface for its overall length, the Cribus 2800 E sets the standard in the compact class. Its large-diameter drum improves screening performance, and generous spacing between drum and sidewalls ensures trouble-free screening even for coarse sizes. This, plus the easy operation and high economy of the Cribus 2800 E make it perfect for a wide array of applications.

Contractors will appreciate the fact that due to the short length, a second drum can be transported by one truck. The use of interchangeable screening segments of highly wear resistant spring steel is particularly beneficial for multi-site use, as different mesh sizes can be transported with the screening machine (available for all types).

Details

Drive	
Electrical power input (kW):	25
Diesel generator (kVA):	59.5 / ~ 64 HP
Material feeding	
Hopper volume:	> 6.5 yd ³ > 5.0 m ³
Screening drum	
Length:	15' 1" 4600 mm
Diameter:	7' 3" 2200 mm
Dimensions	
Transport dimensions L x W x H:	34' 9" x 8' 4" x 13' 1" 10600 x 2550 x 4000 mm
Throughput (dependent on material)	
Throughput performance:	up to 220 yd ³ /h up to 170 m ³ /h



04

Drum change in 5 minutes

Just fold down the sidewall for full drum access. To change the drum, the operator needs only to move the hopper forward, press a button to raise the drum, and then remove it with a loader. Experienced operators can do it in just a few minutes.



05

Right today, left tomorrow

The Cribus can be ordered with the fines discharge conveyor installed on either side, without affecting function. For users who want to stay flexible, an option is available that lets them switch the discharge side on-site. The corrugated belt conveyor gives high performance with low wear, and allows high material piles.

CRIBUS 3800 E

A step ahead through innovation.

A drum diameter of 7' 3" / 2200 mm and an effective screen length of 18' 1" / 5500 mm make the Cribus 3800 E currently the largest mobile drum screen with central axle trailer. The large drum diameter and wide clearance to the sidewalls allow smooth screening of fractions with larger shapes and sizes, even with large screen hole sizes. The drum length gives good screening throughput and output quality.

To keep the Cribus E-series within statutory transport dimensions, the fine particle discharge belt is folded in next to the hopper for transportation, and moved out to the working position next to the drum with a patented movement mechanism.

A sturdy exterior shell, premium quality components, convenient operation, high operational safety and numerous options make the Cribus E a valuable tool for tough daily usage.



Plenty of room in the hopper

- » Steep sidewalls prevent bridging
- » Automatic hopper belt controller for precise straight line travel
- » Hopper wall extensions can be fitted on right or left



Efficient drum drive

- » Maintenance-free drum drive with high-efficiency friction wheels
- » Even support wheel load through all-wheel drive minimizes wear
- » WHEELGRIP anti-slip control prevents slippage

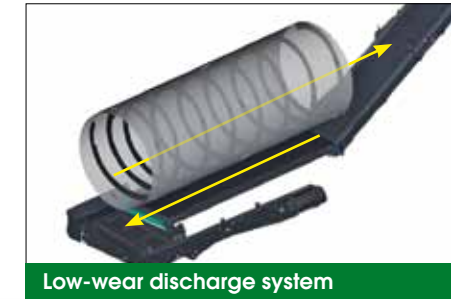

Low-wear discharge system

- » Collection conveyor moves against the material movement in the drum
- » Lower conveyor load reduces wear and energy consumption
- » Corrugated side and fines discharge conveyor prevents leakage



Excellent maintenance access

- » Sidewall can be moved out hydraulically
- » Drum change is possible in a few minutes, without tools
- » Large panels and doors give ready access to all maintenance points



Clean drum

- » Electrically adjustable round brushes, with remote control if desired
- » Wide (5 1/2" / 140 mm) clearance between drive and sidewalls prevents clogs



HYBRID DRIVE: ELECTRIC SOCKET OR GENERATOR

- » Ready for ground power, with diesel generator option
- » Motor slides out hydraulically for maintenance



Nice to have

- » Hopper pre-screening, hopper sensor controller
- » Remote control, feed device
- » Central lubrication, Cleanfix fan and more



01
Electrically adjustable round brush

02
Steep hopper walls with extensions that can be fitted on the right or left

03
Friction wheel drum drive with WHEELGRIP

04
Diesel generator hydraulically extendable

05
Discharge of fines with corrugated belt conveyor

Details

Drive	
Electrical power input (kW):	30
Diesel generator (kVA):	59.5 / ~ 64 HP
Material feeding	
Hopper volume:	> 6.5 yd ³ > 5.0 m ³
Screening drum	
Length:	19' 8" 6000 mm
Diameter:	7' 3" 2200 mm
Dimensions	
Transport dimensions	39' 4" x 8' 4" x 13' 1"
L x W x H:	12000 x 2550 x 4000 mm
Throughput (dependent on material)	
Throughput performance:	up to 290 yd ³ /h up to 220 m ³ /h



HIGHLIGHTS

- » The largest semitrailer-mobile drum screen
- » 25' 3" / 7.7 meter drum length for excellent screening results, even with small hole sizes
- » Minimal energy, wear, and maintenance costs
- » High degree of maintainability with optimum accessibility and zero-maintenance solutions



CRIBUS 5000 E GO BIG

The Cribus 5000 E opens up a new dimension in drum screening. 538 ft² / 50 square meters of screening area along a 25' 3" / 7.7 meter long drum and a hopper holding over 8.5 cubic yard / 6 cubic meters make it obvious who we designed this high-performance machine for - for users who want high throughput with great screening results, especially with small hole sizes.

For that, there is no substitute for drum length. But we did substitute the hydraulic drive - on this model, everything is electric. That minimizes energy, wear, and maintenance costs, and makes the big Cribus one of the most economical machines in its class.



01

Saving energy with hybrid technology

The power for the electrical drives comes directly from the grid or is generated by an integrated diesel generator.

Savings potential compared to diesel hydraulic drives:

- In mains mode:
 - » up to 75% lower energy consumption
 - » up to 30% lower consumable parts costs
 - » up to 25% lower operating costs
 - » no servicing of the diesel unit or hydraulics unit
- In generator mode:
 - » up to 25% lower energy consumption
 - » up to 15% lower consumable parts costs
 - » up to 5% lower operating costs
 - » no servicing of the hydraulic system



02

Little holes - big performance

With small hole sizes (<3/4" / < 20 mm) in particular, the length of the drum and its effective screening area become crucial factors. On its way through this 25' 3" / 7.7 m drum, all the material is thoroughly screened.



03

High degree of operator convenience

Thanks to its fully electronic control, this drive design features the highest ease of use. The display mode shows the operating status, and all functions are clearly visible and easily configurable. An automatic start-up and idling feature simplifies starting, and load-dependent hopper control prevents overloading of the screen drum.



04

Ready to go

Despite its impressive size, the Cribus is easy to maneuver as a semitrailer. Operation and maintenance are also simple and convenient. The operating panel with graphic control, automated starting and electric brush adjustment, plus options like hopper sensor control, remote control, hopper pre-screen and more, make this machine exceptionally operator-friendly.



05

Plenty of room in the hopper

The hopper is sized to match the high screening throughput. Its 8.5 yd³ / 6 m³ volume and 15' 5" / 4.7 meter loading length make for easy loading with even large frontloaders. On the all-electric version without diesel auxiliary generator, the space saved results in a hopper volume over 10.5 yd³ / 8 m³.

Details

Drive	
Electrical power input (kW):	36
Diesel generator (kVA):	59.5 / ~ 64 HP
Material feeding	
Hopper volume:	> 8.5 yd ³ / > 6 m ³
Screening drum	
Length:	25' 3" / 7700 mm
Diameter:	7' 3" / 2200 mm
Dimensions	
Transport dimensions	46' 1" x 8' 4" x 13' 1"
L x W x H:	14000 x 2550 x 4000 mm
Throughput (dependent on material)	
Throughput performance:	up to 350 yd ³ /h up to 270 m ³ /h



	Cribus 2800 E	Cribus 3800 E	Cribus 5000 E
Drive			
Electrical power input (kW)	25	30	36
Diesel generator (kVA):	59.5 / ~ 64 HP	59.5 / ~ 64 HP	59.5 / ~ 64 HP
Material feeding - feed hopper			
Hopper volume:	> 6.5 yd ³ / > 5.0 m ³	> 6.5 yd ³ / > 5.0 m ³	> 7.8 yd ³ / > 6.0 m ³
Filling length:	> 13' 1" / > 4000 mm	> 13' 1" / > 4000 mm	> 15' 5" / > 4700 mm
Filling width:	5' 6" / 1675 mm	5' 6" / 1675 mm	5' 6" / 1675 mm
Filling height:	9' 8" / 2950 mm	9' 8" / 2950 mm	9' 8" / 2950 mm
Screening drum			
Diameter:	7' 3" / 2200 mm	7' 3" / 2200 mm	7' 3" / 2200 mm
Length:	15' 1" / 4600 mm	19' 8" / 6000 mm	25' 3" / 7700 mm
Effective screening area:	301 ft ² / 28 m ²	409 ft ² / 38 m ²	538 ft ² / 50 m ²
Drum rpm:	max. 20	max. 20	max. 20
Material discharge (standard)			
Max. discharge height coarse fraction:	8' (Option 11' 6") 2450 mm (Option 3500 mm)	11' 6" 3500 mm	11' 6" 3500 mm
Max. discharge height fine fraction:	7' 5" (Option 11' 0") 2250 mm (Option 3350 mm)	11' 0" 3350 mm	11' 0" 3350 mm
Dimensions			
Transport dimensions L x W x H:	34' 9" x 8' 4" x 13' 1" 10600 x 2550 x 4000 mm	39' 4" x 8' 4" x 13' 1" 12000 x 2550 x 4000 mm	46' 1" x 8' 4" x 13' 1" 14000 x 2550 x 4000 mm
Working dimensions L x W x H:	43' x 16'5" x 13'1" / 13100 x 5000 x 4000 mm (Option: 48'11" x 21'6" x 13'1" / 14900 x 6560 x 4000 mm)	53' 6" x 21' 6" x 13' 1" 16300 x 6560 x 4000 mm	60' 8" x 22' 4" x 13' 1" 18350 x 6560 x 4000 mm
Weight (t):	< 17.6 t.sh / < 16.0 t	< 20 t.sh (21 t.sh) / < 18.0 t (19.0 t)	< 29 t.sh / < 26.0 t
Throughput (dependent on material)			
Throughput performance:	up to 220 yd ³ /h / 170 m ³ /h	up to 290 yd ³ /h / 220 m ³ /h	up to 350 yd ³ /h / 270 m ³ /h
Options			
Diesel generator, Cleanfix fan, magnet drum, adjustable belt speed, scraper for round brush, central lubrication, hopper pre-screening, hopper sensor control, remote control, feed device, attachment shoe and more			

CRIBUS 2800 E

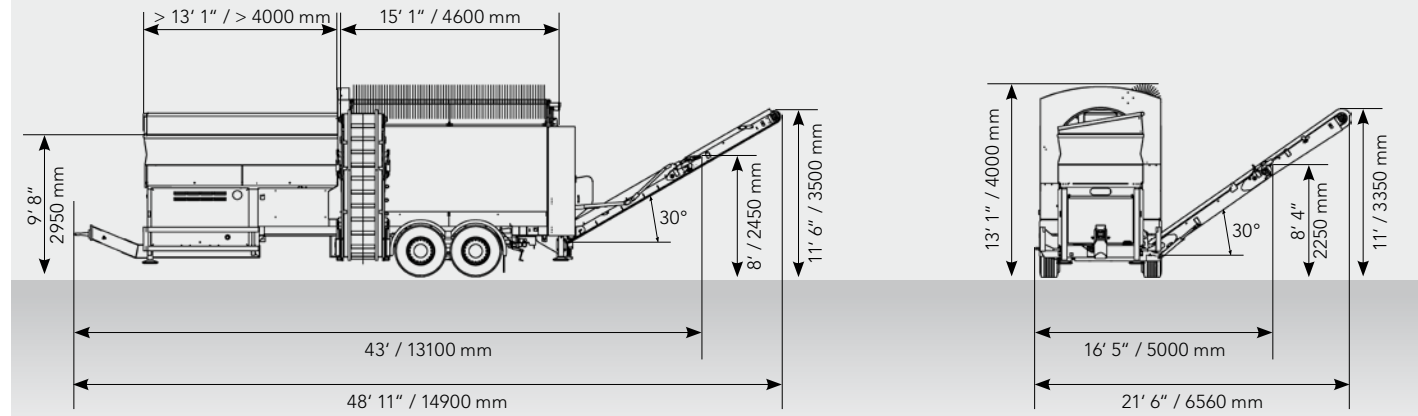

CRIBUS 3800 E

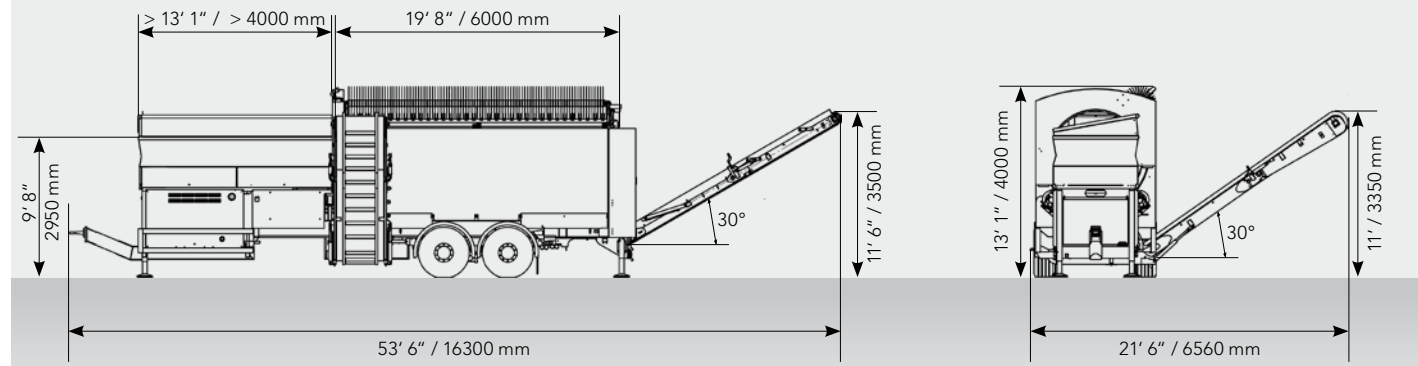

CRIBUS 5000 E

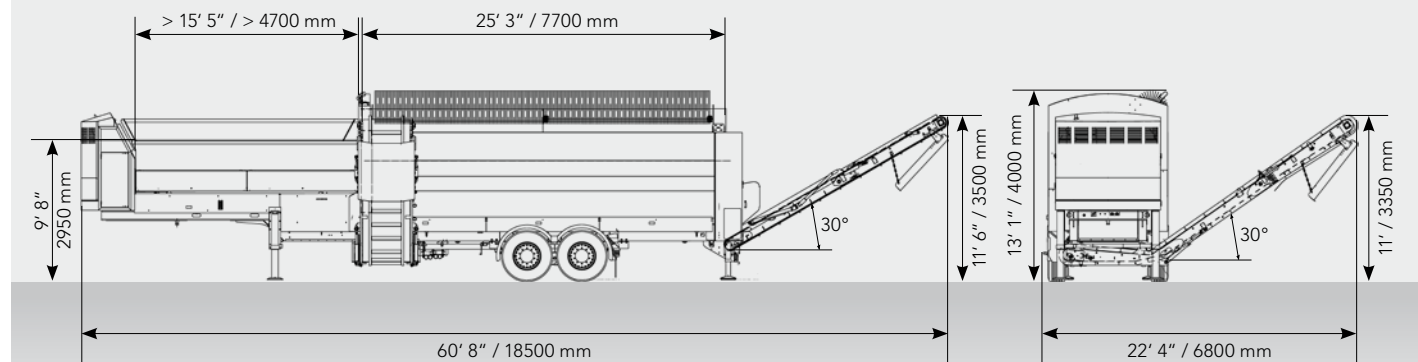

TECHNOLOGY FOR A BETTER **ENVIRONMENT**



Komptech USA Inc.
[P] (720) 890-9090
[F] (720) 890-5907
[E] info@komptechusa.com

www.komptechusa.com

We reserve the right to make technical changes due to ongoing development. USA2012