

NEMUS 2700

HYDRAULIC MOBILE DRUM SCREEN





HIGHLIGHTS



- » More than 6.5 yd³/5 m³ hopper for constant operation
- » Efficient, low-wear hopper belt drive on the drum intake side
- » 323 ft² / 30 m² screening area for higher throughput and more efficiency per ft² / m² screening area
- » DRUMGRIP drive, combining the toughness of a chain and the smoothness of a friction drive
- » Uses Mustang and Doppstadt drums
- » One-piece corrugated edge fines discharge belt eliminates transfer loss
- » New control design for easier, self-explanatory operation



THE NEMUS

With the Nemus 2700, Komptech is launching a new generation of mobile hydraulic drum screens. As the successor to the Mustang, the Nemus combines all the positive features and experience of its predecessor, while adding new features from the Cribus series. The large hopper in the design of the Cribus, the screen drum with its improved material feed and the one-piece corrugated edge fines discharge belt harmonize perfectly with the proven, robust diesel-hydraulic drive.

Redesigned controls make operation easier, and the extended discharge belts included as standard equipment allow for more flexibility. Customer feedback is always important to us. We've incorporated their suggestions such as an easy cleaning radiator screen, larger support wheels, and new low-wear conveyor scrapers. The Nemus, the best of both worlds.



A
Hopper belt is driven on the screen intake side

B
Electronic control panel with a visual display

C
Discharge of fines with corrugated belt conveyor

D
Low wear DRUMGRIP-drum drive

E
Steep hopper walls with extensions that can be fitted on the right or left



01

Flexible drum choices

Now it is easy for existing drum screen users to switch – the Nemus 2700 takes Mustang drums, as well as drums from the Doppstadt SM 720. Within the drum itself, the improved material flow gives up to 10% more throughput. The greater clearance between drum and sidewall allows a wide range of materials with hole sizes up to 4"/100 mm.



02

Clean discharge

The fine particles are discharged by a one-piece corrugated edge belt. The one-piece design prevents material spillage at transfer points, while also giving high capacity and low wear. Both discharge belts are longer than on the Mustang, offering a discharge height of 10'6"/3.2 m in standard configuration.



03

Maintenance made easy

Numerous details reduce maintenance effort, time and expense, like the simplified diesel engine radiator cleaning, easier hopper belt replacement, the fines collection belt that comes out as a one-piece cartridge, and the elimination of rubber wear elements on the discharge belts.

Nemus 2700

* extended discharge belts

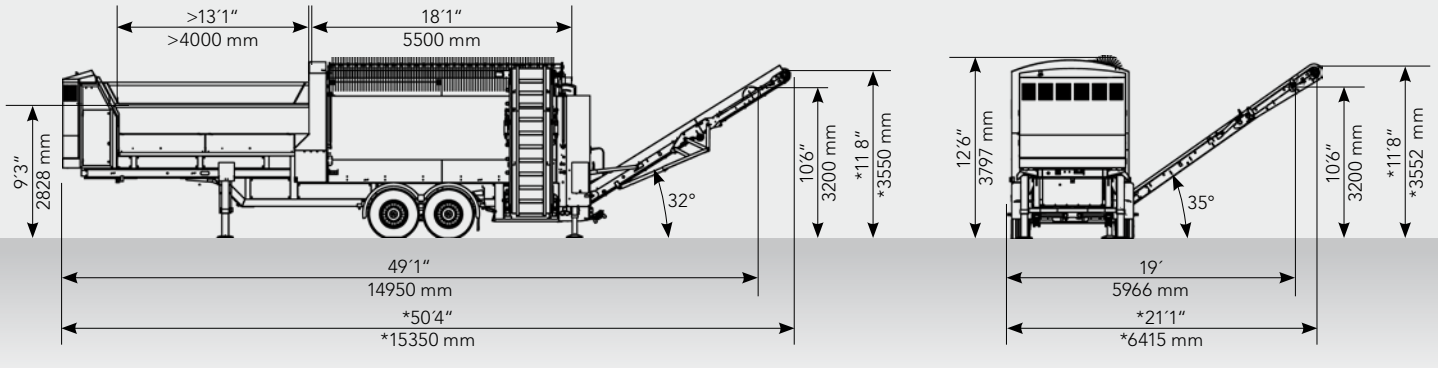

NEMUS 2700

Drive	
Diesel engine (kW / HP):	70 / 94
Material feeding - feed hopper	
Hopper volume:	> 6.5 yd ³ / > 5.0 m ³
Feeding length:	> 13'1" / > 4000 mm
Feeding width:	5'6" / 1675 mm
Feeding height:	9'3" / 2828 mm
Screening drum	
Diameter:	6'7" / 2000 mm
Length:	18'1" / 5500 mm
Effective screening area:	323 ft ² / 30 m ²
Drum rpm:	max. 23
Material discharge	
Max. discharge height coarse:	11'8" / 3550 mm
Max. discharge height fine fraction:	11'8" / 3552 mm
Dimensions	
Transport dimensions L x W x H:	37'11" x 8'4" x 13'1" 11552 x 2550 x 4000 mm
Working dimensions L x W x H:	50'4" x 19'7" x 12'6" 15350 x 5966 x 3797 mm
Weight:	18.5 t.sh / 17.0 t
Throughput (dependent on material)	
Throughput performance:	up to 220 yd ³ / 170 m ³ /h
Options	

Conveyor extensions, magnet drum, scraper for round brush, central lubrication, hopper pre-screening, hopper sensor controller, remote control, air suspension, Cleanfix fan, hydraulic extendable engine, feed device, attachment shoe, adjustable belt speed and more



Komptech Americas LLC
 [P] (720) 890-9090
 [F] (720) 890-5907
 [E] info@komptechamericas.com

www.komptechamericas.com

We reserve the right to make technical changes due to ongoing development. 2015