

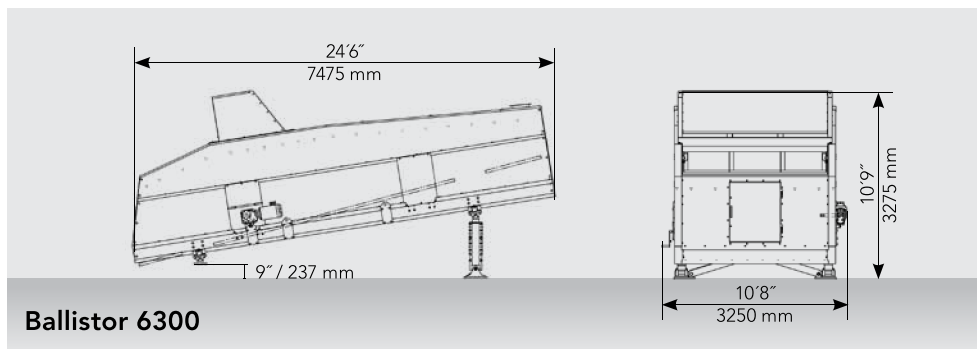

# BALLISTOR BETTER SEPARATION

The Ballistor is used to separate out usable fractions from waste and potential recyclables. By combining ballistic separation with screening, separation is performed in one operation in accordance with the criteria 3/2-dimensional, rolling-cubic-rigid/flatsoft-narrow, or undersized/oversized particles. The Ballistor separator can be configured to suit many applications.

Other methods like screening followed by windsifting involve a conveyor and take substantially more space and energy. The Ballistor's long-life components, readily replaceable wear elements, and excellent maintenance access further reduce operating costs.



**Ballistor 6300**

	4300	6300	8300	10300	12300
<b>Drive</b>					
Power (kW/HP):	5.5/7.3	5.5/7.3	11.0/14.7	11.0/14.7	11.0/14.7
<b>Dimensions</b>					
Length:	24'6" 7475 mm	24'6" 7475 mm	24'6" 7475 mm	24'6" 7475 mm	24'6" 7475 mm
Width:	7'10" 2400 mm	10'8" 3250 mm	13'5" 4100 mm	16'3" 4960 mm	19'1" 5810 mm
Height without inlet cap:	6'4" 1930 mm	6'4" 1930 mm	6'4" 1930 mm	6'4" 1930 mm	6'4" 1930 mm
Transport Width (pre-assembled machine, reduction by decomposition possible)	7'1" 2150 mm	9'10" 3000 mm	12'11" 3940 mm	15'9" 4800 mm	18'6" 5650 mm
<b>Screen</b>					
Number of fractions:	3	3	3	3	3
Number of screening elements:	4	6	8	10	12
Length screening elements:	18'4" 5600 mm	18'4" 5600 mm	18'4" 5600 mm	18'4" 5600 mm	18'4" 5600 mm
Screening area:	104 ft <sup>2</sup> 9.6 m <sup>2</sup>	155 ft <sup>2</sup> 14.4 m <sup>2</sup>	207 ft <sup>2</sup> 19.2 m <sup>2</sup>	257 ft <sup>2</sup> 23.9 m <sup>2</sup>	309 ft <sup>2</sup> 28.7 m <sup>2</sup>
<b>Weight</b>					
Weight, machine only:	~ 6.4 t.sh ~ 5.75 t	~ 7.7 t.sh ~ 7.0 t	~ 9.4 t.sh ~ 8.5 t	~ 10.8 t.sh ~ 9.75 t	~ 12.1 t.sh ~ 11.0 t
<b>Throughput</b> (dependent on material)					
Throughput performance:	to 80 yd <sup>3</sup> /h to 60 m <sup>3</sup> /h	to 130 yd <sup>3</sup> /h to 100 m <sup>3</sup> /h	to 170 yd <sup>3</sup> /h to 130 m <sup>3</sup> /h	to 210 yd <sup>3</sup> /h to 160 m <sup>3</sup> /h	to 262 yd <sup>3</sup> /h to 200 m <sup>3</sup> /h

**Options**  
Screening plates in various designs, perforation (30/50/60/80 mm) and material texture, central lubrication crankshaft bearing, automatic grease cups connecting rod bearing, fixed or manual inclination, in-feed hood, tarpaulin cover and more

## HIGHLIGHTS

- » Wide range of applications – from municipal waste (household waste, commercial waste) to potential recyclables and construction and demolition waste
- » High degree of selectivity with adjustable separation limit
- » Efficient drive design with low power requirements
- » Rugged design with long service life and low operating costs
- » Compact design requires small footprint

